

READ THIS HANDBOOK IMMEDIATELY.

These instructions are provided for your safety and to facilitate the assembly of the RIO umbrella.

Please follow the instructions carefully.

Failure to do so may result in injury or damage. If in doubt contact your dealer.

△ **This symbol indicates very important information. Follow instructions accompanied by this symbol with extreme care. This does not mean that the other information contained in this handbook is not important. Please keep this handbook for future reference.**

△ **APPLIES TO ALL IN THIS SECTION**

1. INSTRUCTIONS: Please read and follow all the instructions.

Damage or injury may result if the umbrella is not assembled and used as described herein.

For safe use it is essential that anyone using the umbrella read all the instructions in advance. Only persons familiar with the safety aspects should operate this umbrella.

2. PRECAUTIONS: The RIO umbrella serves as a protection from the sun, not as protection from all bad weather. It must be closed and removed from the frame in the presence of strong winds or thunderstorms, as well as heavy rain or snow. Always close and remove the umbrella from its frame at night, when you are not at home and whenever it is not under control. The base must be weighed down with a minimum weight of 100 kg (200 lbs).

ASSEMBLY INSTRUCTIONS

COMPONENTS (fig. 1):

A-Base channel(A) B-Base channel(B) B'-Base extensions(B')
C-Base tube D-Vertical pole E-Cantilever pole F-Umbrella top
M-Bag of hardware

BASE ASSEMBLY (fig. 2 - fig. 2 Bis)

Assemble the base as shown in fig 2.

Place four concrete slabs in position in the base.

IMPORTANT: the two holes (a) in the base tube (C) must match the two holes (a') of base channel(B).

△ : **Tighten the base bolts well.**

△ : **Ballast the base with a weight of at least 100 KG (200 lbs).**

FRAME ASSEMBLY

(Fig. 3 - fig.3a - fig. 3b - fig. 3c - fig. 3d)

1. (fig 3a) Slip the cantilever pole (E) over the vertical pole (D) and lock the two parts with the bolt (P).

△ : **Tighten the bolt (P) well.**

2. (fig 3b) Slide the vertical pole (D) over the base tube (C).

△ : **The vertical pole (D) must be pushed all the way into the square housing of the adjustment ring (O).**

3. (fig. 3c) grip the umbrella and slip the umbrella attachment (R) into the cantilever pole (E)

△ : **The umbrella attachment (R) must be pushed all the way into the cantilever pole (E).**

4. (fig.3) pass the nylon cord (Z) through the pulley (S).

5. Pull on the handle (G) to open the umbrella. You may need to unfold the fabric first to facilitate opening.

6. While maintaining tension on the cord, insert it into the rope cleat on the elbow. To secure it, snake the cord several times through the slot bar below the cleat.

Your RIO is now ready for use.

ROTATION OF THE UMBRELLA AROUND THE BASE (fig. 5 - fig. 2)

The frame can rotate 360° around the base and can be fixed in 20 different positions by inserting the key (U) into the adjustment ring (O) (Fig.5).

IMPORTANT:

The key (U) must be inserted into the adjustment ring (O) at hole (a) of the base pole (C) (fig. 2).

REMOVAL OF THE UMBRELLA FROM THE FRAME (fig. 3 - fig. 6)

1. Close the umbrella by pulling the cord out of the rope cleat.
2. Remove the nylon cord (Z) from the pulley (S). Remove the umbrella (F) from the frame by removing attachment (R) from the cantilever pole (E).

WASHING THE COVER

1. Remove the cover from the umbrella.
2. Wash the cover by hand in lukewarm water 30 °C (90 °F)
3. Allow the cover to dry but do not tumble dry or iron.
4. Replace the cover on the frame.

CHANGING A RIB (FIG. 7a - 8 - 8a)

1. Release the 6 tabs from the 6 ribs (W) (fig. 7a)
2. Release the rib to be changed (W) from the housing (Y') pulling forcefully upwards (fig.8).
3. Rotate the rib (W) 180° and release the other end from the band (Y'') pulling firmly upwards (fig. 8a).
4. Change the rib repeating the above operations in reverse.

STORING THE UMBRELLA AT THE END OF THE SEASON

At the end of the season, before storing your RIO away, clean the frame with a damp cloth and dry.

△ : **Check that no parts are damaged. Should any parts be damaged contact the dealer where it was purchased and order the spare parts.**

Touch up any chipped paint.

For perfect conservation of the RIO during the winter months store in a dry place.

IMPORTANT: To avoid damage caused by mould or oxidation never put your RIO away when wet or damp.

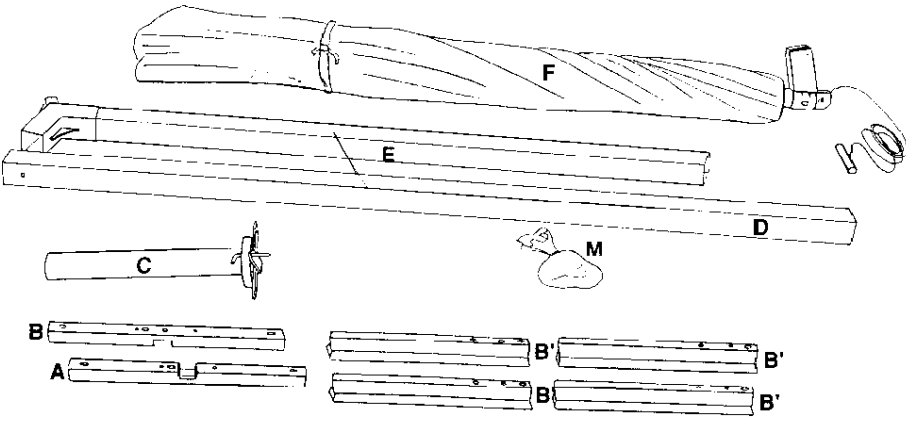

Fig. 1

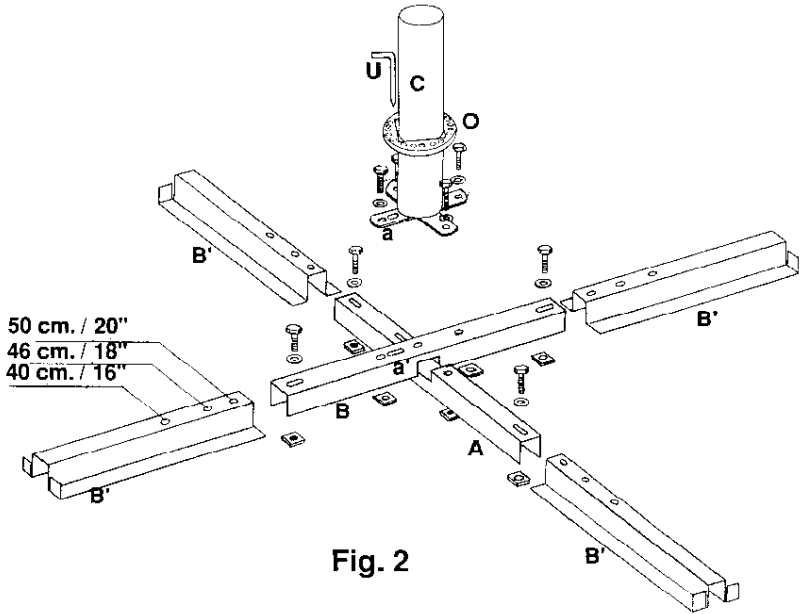

Fig. 2

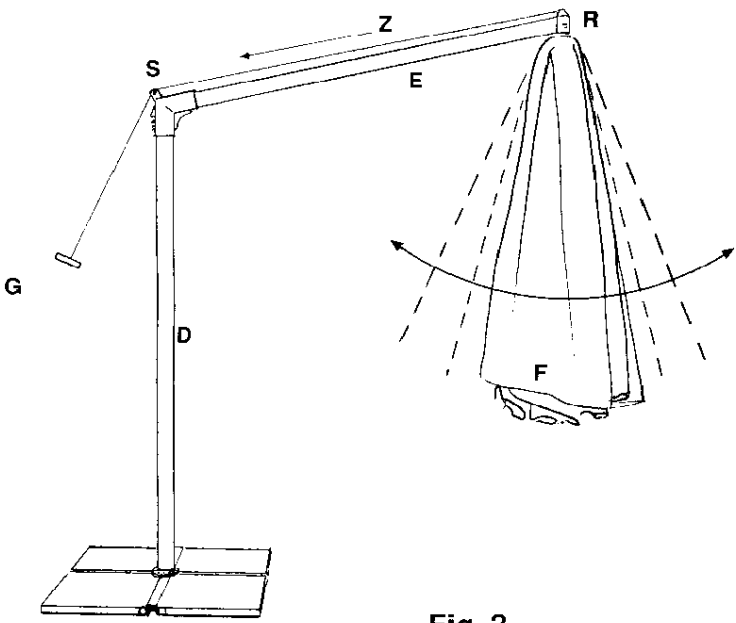

Fig. 3

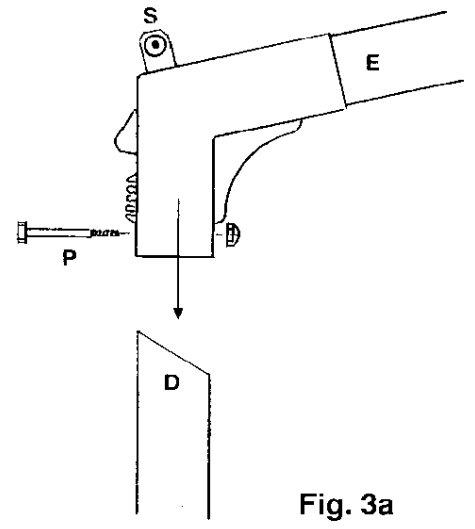

Fig. 3a

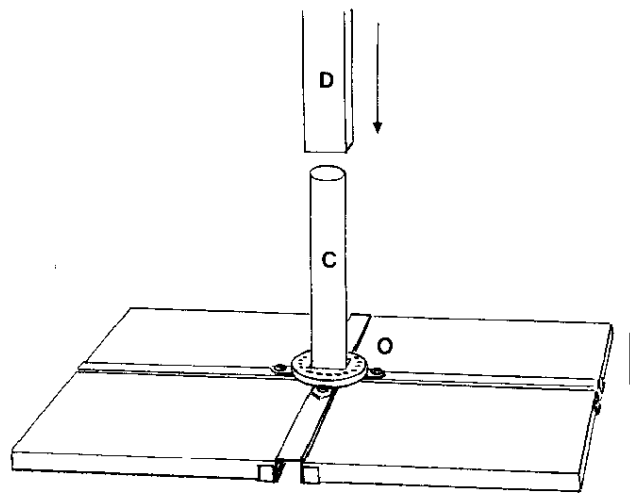

Fig. 3b

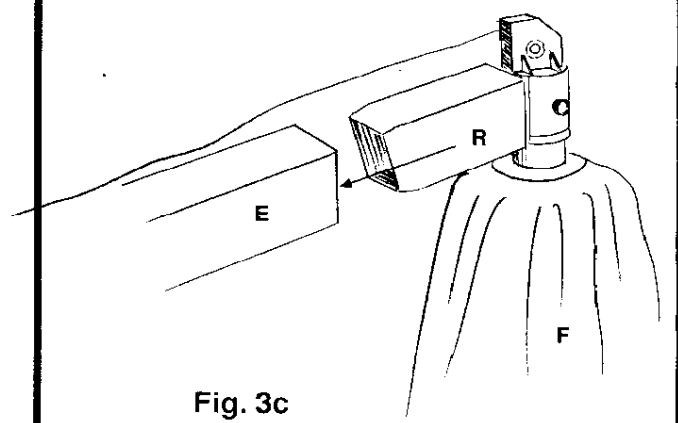

Fig. 3c

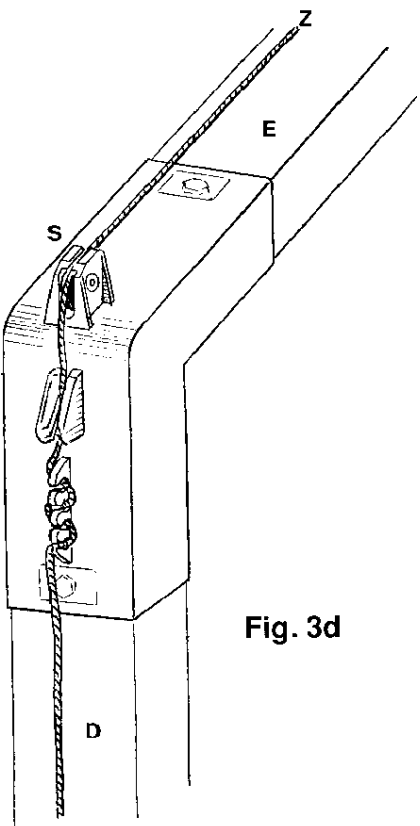

Fig. 3d

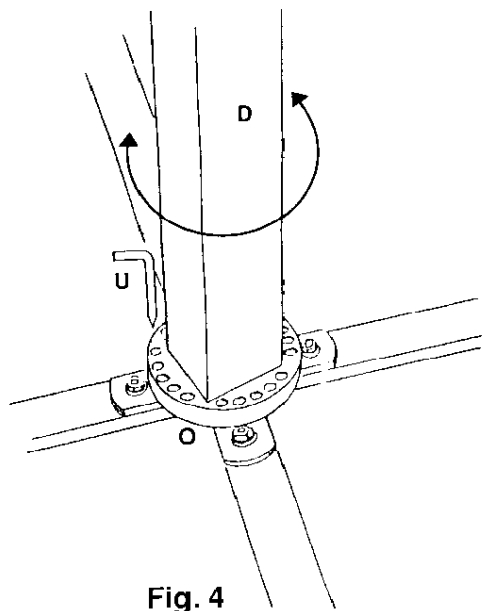

Fig. 4

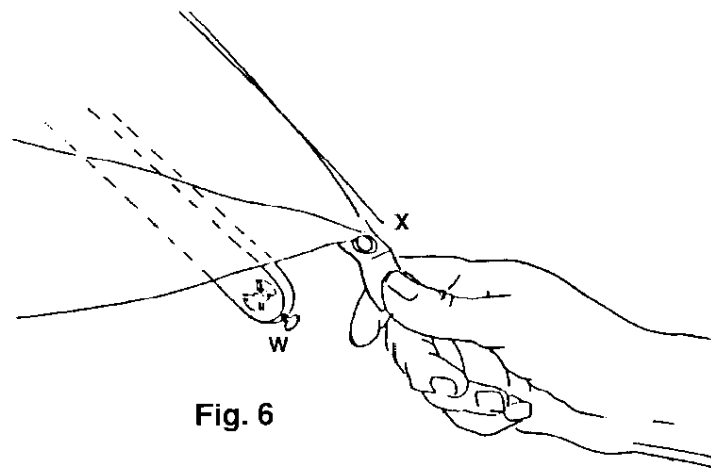
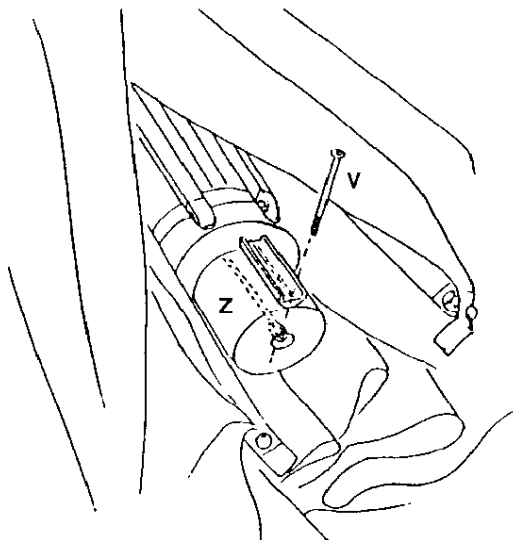

Fig. 6

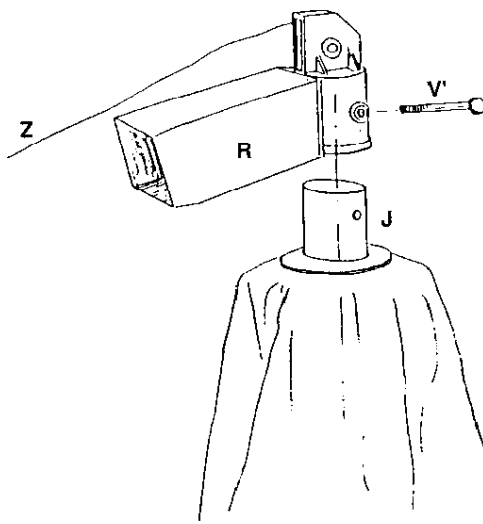

Fig. 7

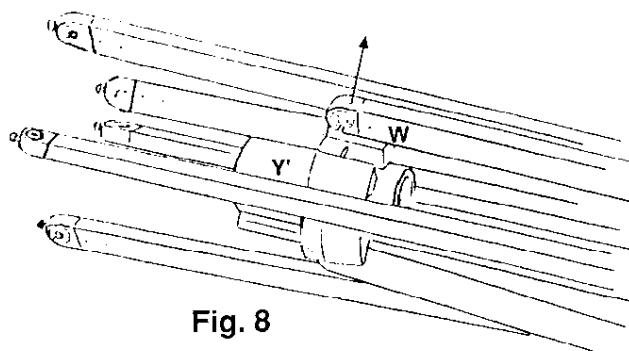

Fig. 8

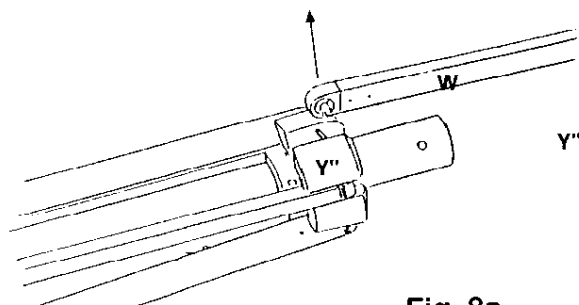

Fig. 9